



# Instruction Manual

FFI Platinum E85 Conversion Kit is a product specially developed for vehicles with multiport fuel injection systems, dual throttle body injection, and digital ignition.

Our product offers the choice of using gasoline, ethanol or any mixture of both.



- The installation is simple and quick. It is compatible with all multipoint injected vehicles including cars, trucks, motorcycles and other powersports.
- It is not a conversion chip.
- It does not alter the vehicle originality.
- It can be removed at any time and transferred to another vehicle.

The FFI Platinum is a fully automatic bi-fuel electronic management system whose functions are controlled by the information received from the vehicle modules (E.C.U.).

It is important that your vehicle is in proper working order and has been well maintained. The fuel pump and the emissions system are important for the proper operation of the FFI Platinum. The fuel pump pressure and flow should be in accordance and within the standards set by the vehicle manufacturer. After confirming the compliance of the data above, you may proceed with the FFI Platinum installation.

Change the oil, oil filter and fuel filter since ethanol will act as a cleaner. It is recommended to change your oil between 500 and 1000 miles after the FFI Platinum installation and E85 usage. Change the fuel filter around 1000 miles after E85 usage. From then on, the changes should be made at manufacturers recommended intervals.

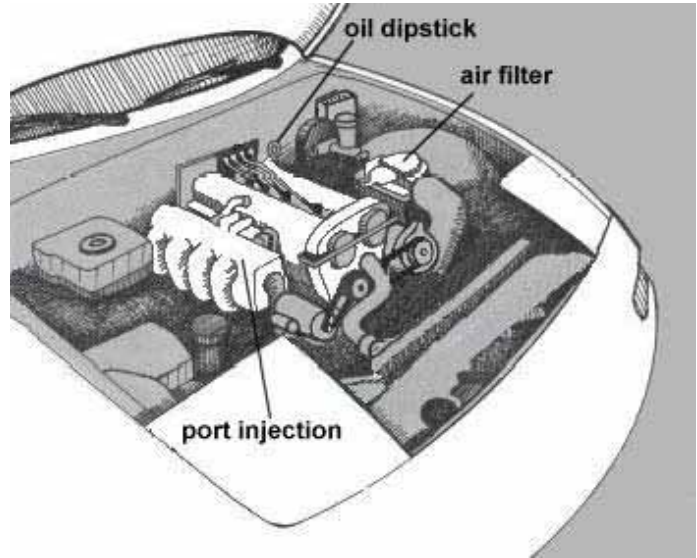
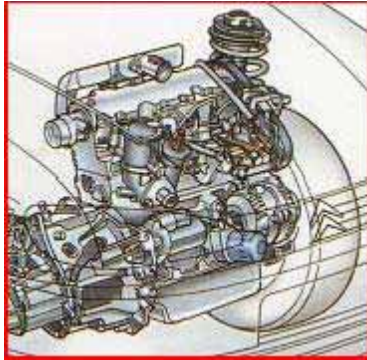

Make sure that all other vehicle sensors are in proper working condition. The FFI Platinum unit needs the proper data to run engine controls to allow normal driving conditions to be met.

**Always check your injector connectors prior to ordering your FFI Platinum.**



**Bosch EV1**



**Bosch EV6**



**Delphi**



**Honda**



**Nippon Denso**



**Toyota**

# FFI PLATINUM SERIES 4 CYLINDER

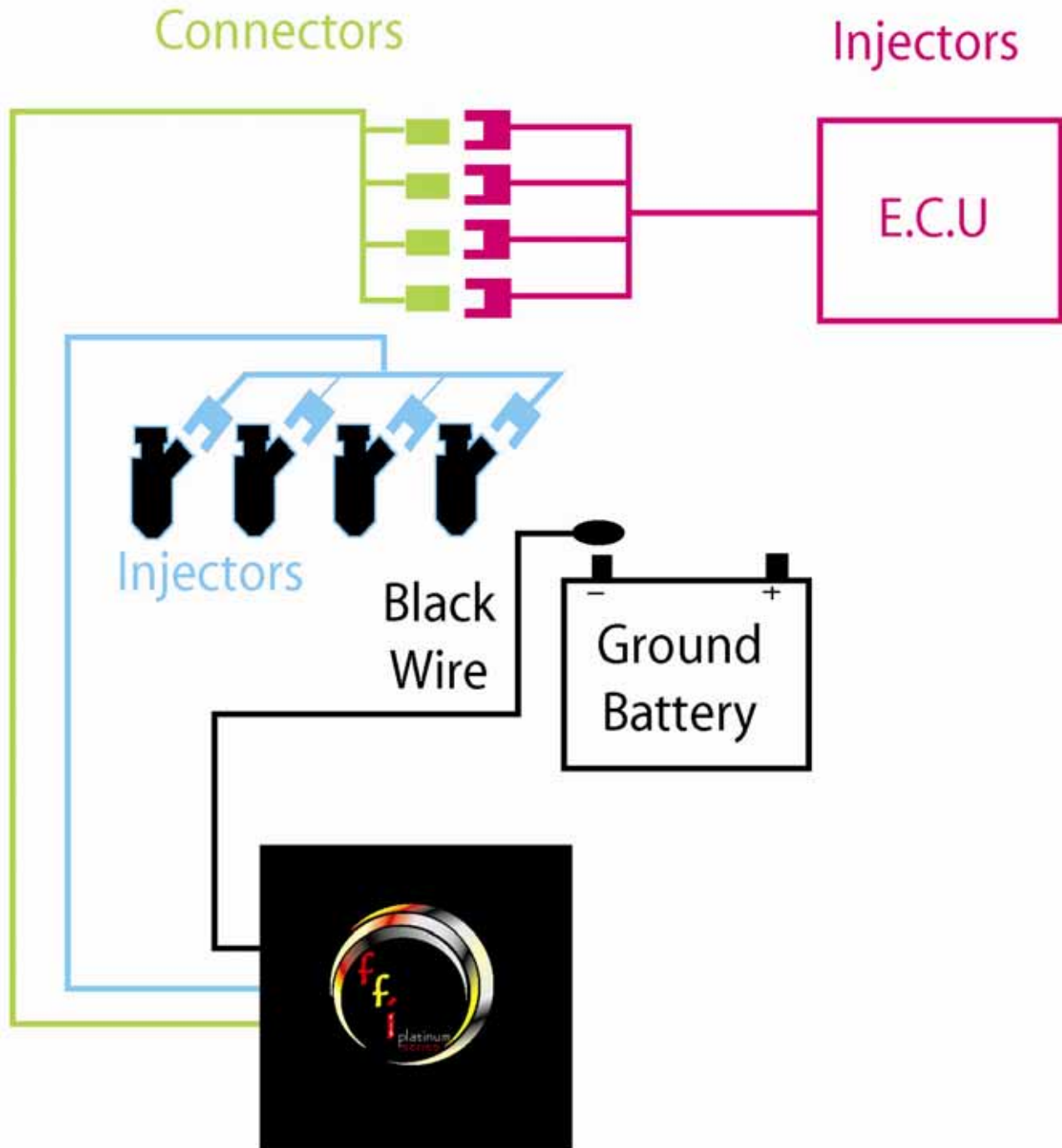

# FFI PLATINUM SERIES 6 CYLINDER

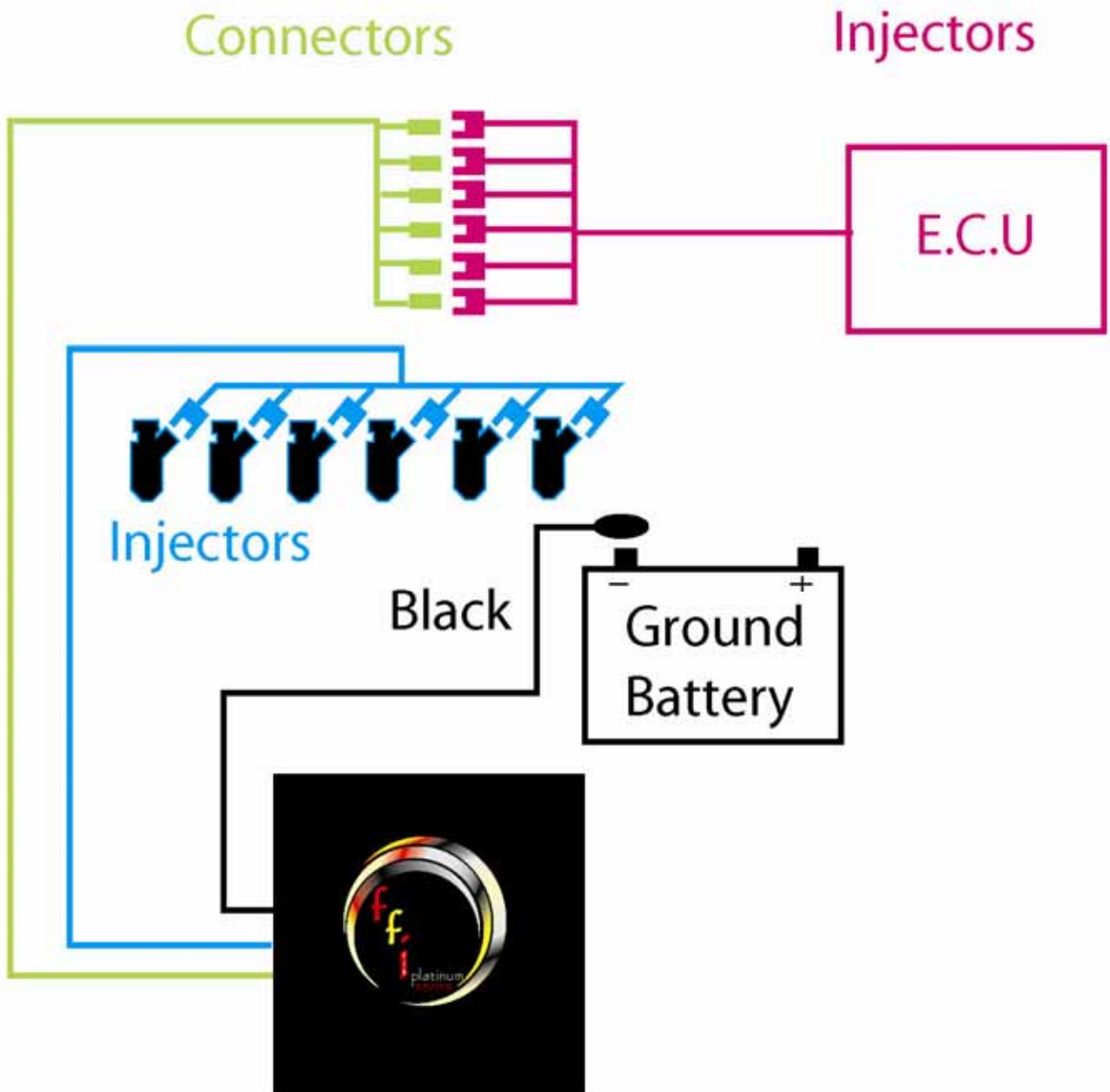

# FFI PLATINUM SERIES 8 CYLINDER

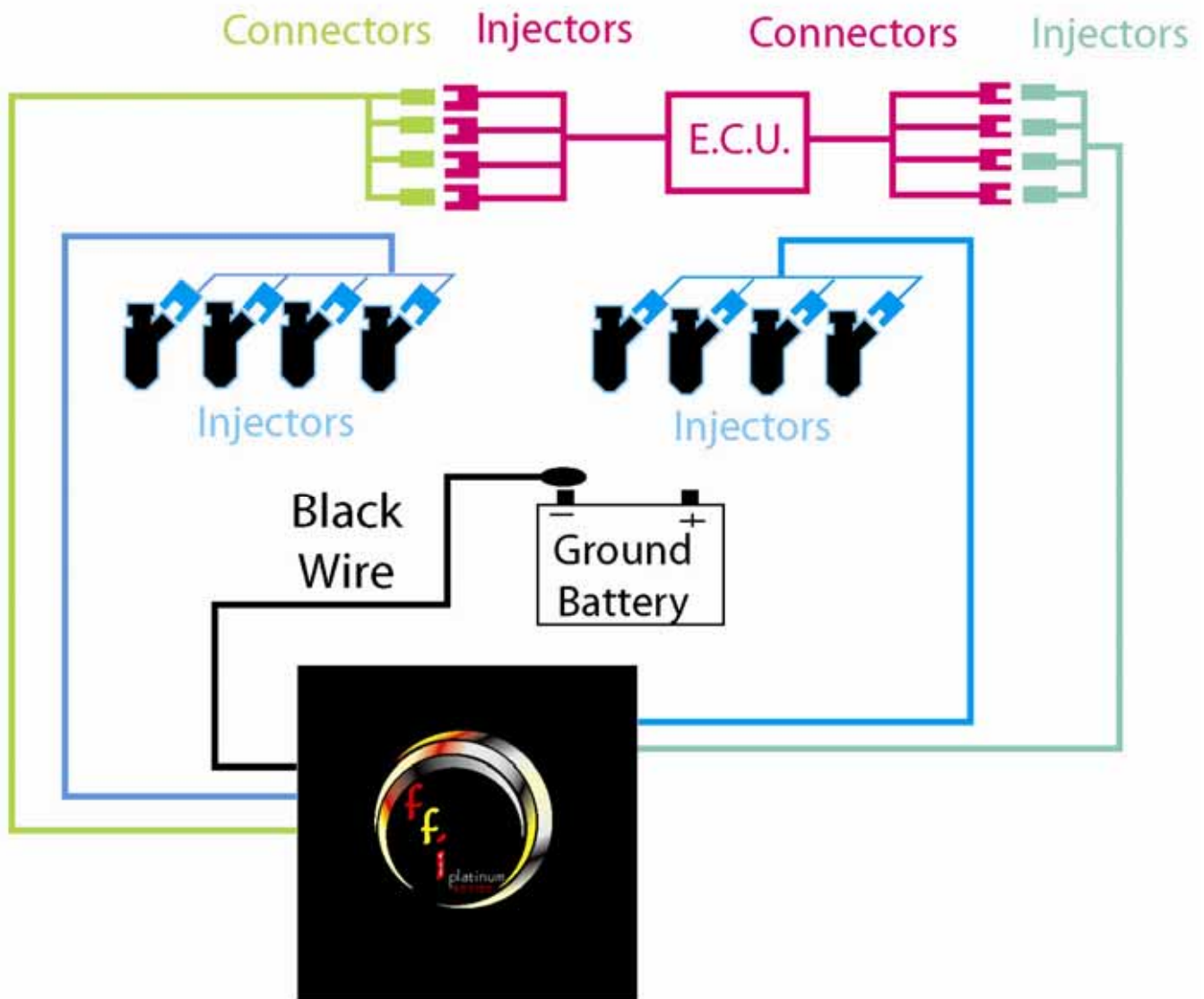

# 6 & 8 Cylinder Digital Vortec installation

X - Cut OEM Wires

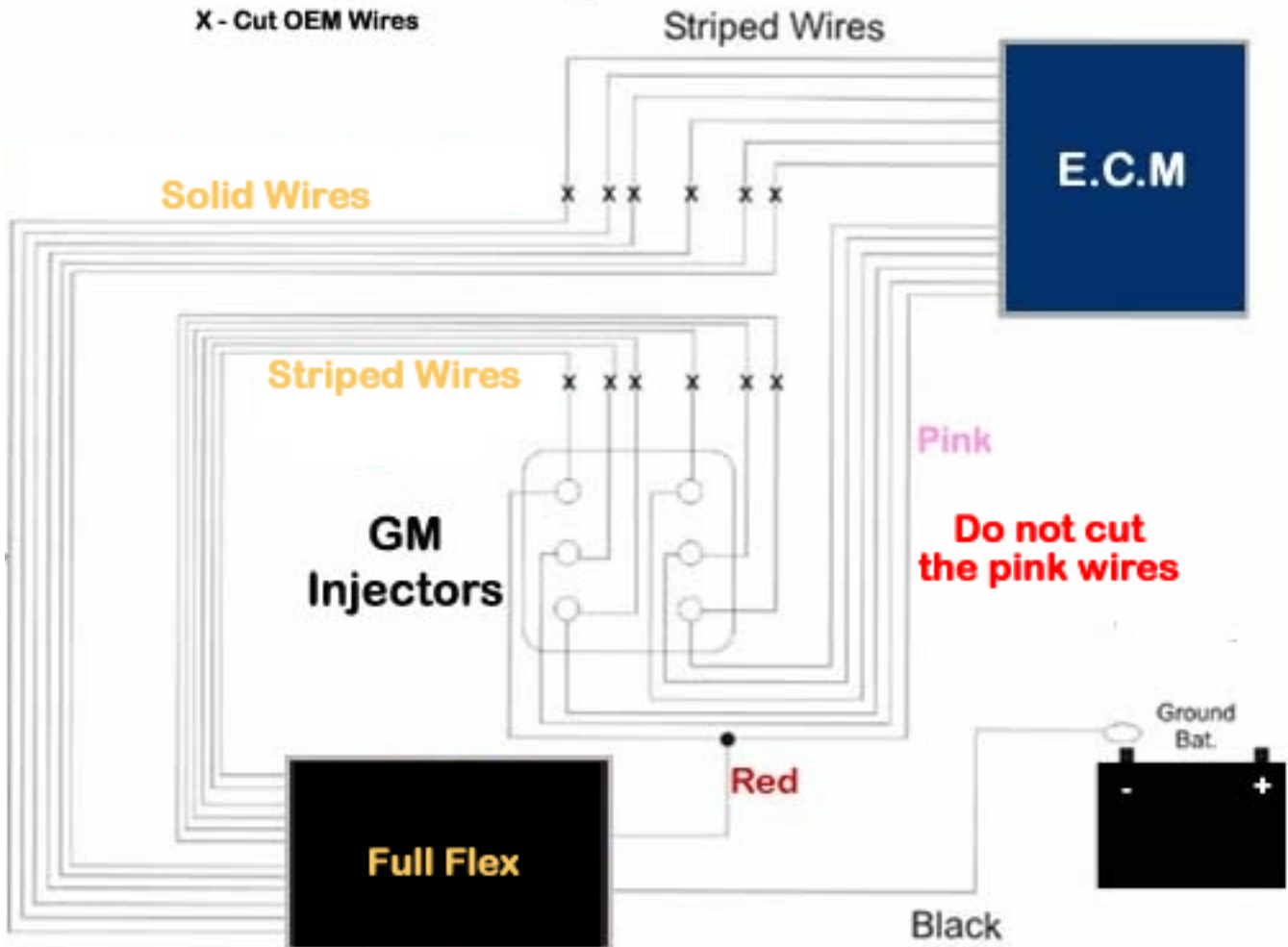

# THROTTLE BODY UNIT

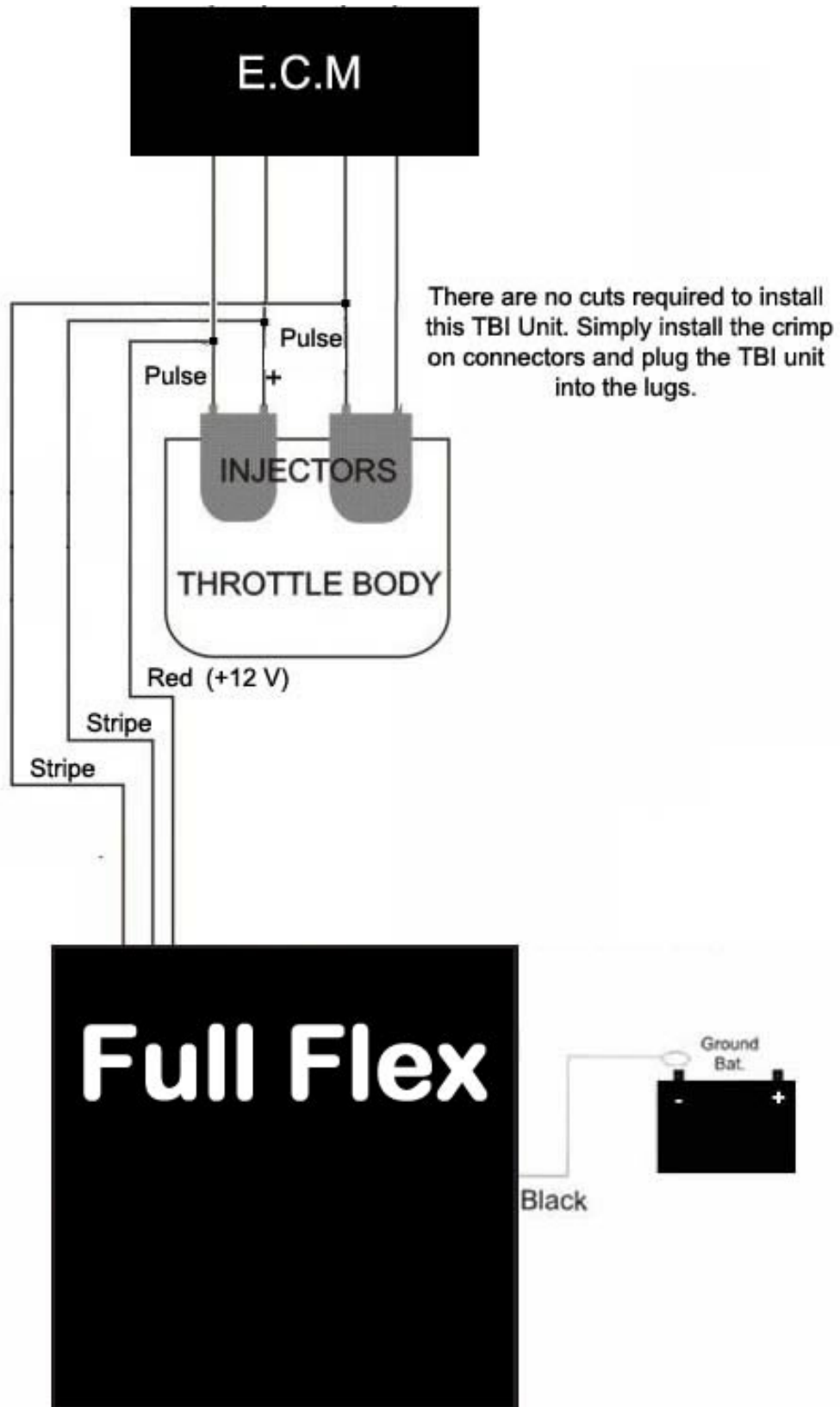



# INSTALLATION

1



**Locate your vehicle's fuel injection connectors**

2



**Release the vehicle injection nozzle connectors**

3



**Take one set of male and female connectors on the FFI Platinum harness to each fuel injector. There is no specific order when attaching the FFI Platinum. Firing order is still controlled by your vehicle's computer.**

4a



**Attach the FFI Platinum female connector on to the vehicle injection nozzle**

4b



**Attach the FFI Platinum male connector into the female connector of the vehicle's injector wiring harness**

# INSTALLATION

5



**Connect the FFI Platinum black wire with the round terminal on the negative battery terminal or any grounding point under the hood. Some FFI Platinum units will have more than one grounding wire. They can both be attached to the same grounding point. A self-tapping screw can also be used to ground to any sheet metal.**

6



**Double check all connectors to ensure they are snug. Fasten the FFI Platinum using Gorilla tape, zip ties, Velcro or self tapping screws.**

**Use lots of zip ties on the FFI Platinum cables to avoid touching the cables on hot engine parts.**



Upon completion of the installation, drive about ten miles. If all is running smoothly, refuel the vehicle with 50% gasoline and 50% E85. This permits the system to calculate new parameters of operation. The next tank should be all E85. Subsequent tanks can be any combination of gasoline or ethanol. In the event your check engine light comes on, give us a call. Your FFI Platinum may require a minor adjustment or there may be a loose connector. If you have any questions during any point of the installation process, please call us.



**There you are! Your FFI Platinum is installed!  
Now enjoy driving while being powered by Ethanol!**